

CE474: Traffic Systems Design-Fall 2004

Class 10 – Actuated Controller Operations
September 27, 2004

Ahmed Abdel-Rahim
Civil Engineering Department, University of Idaho

Actuated Controller setting

- ◆ Maximum green time (MAX 1 or MAX 2) (in seconds) [Maximum extension could be used]
- ◆ Minimum green time (MIN GRN or MIN). Minimum green is the minimum duration (in seconds) of the phase or initial interval (MIN GRN, MIN INI, or INITIAL).
- ◆ Vehicle extension (VEH EXT, PASS, or GAP) (passage time)
 - Vehicle extension (passage time or gap time) is the time that the phase will be extended for each actuation. The minimum value accepted is 1.1 seconds.

Volume/Density Setting

- Time to Extend
- Maximum Extension
- Time Before Reduction
- Time to Reduce
- Seconds Per Actuation

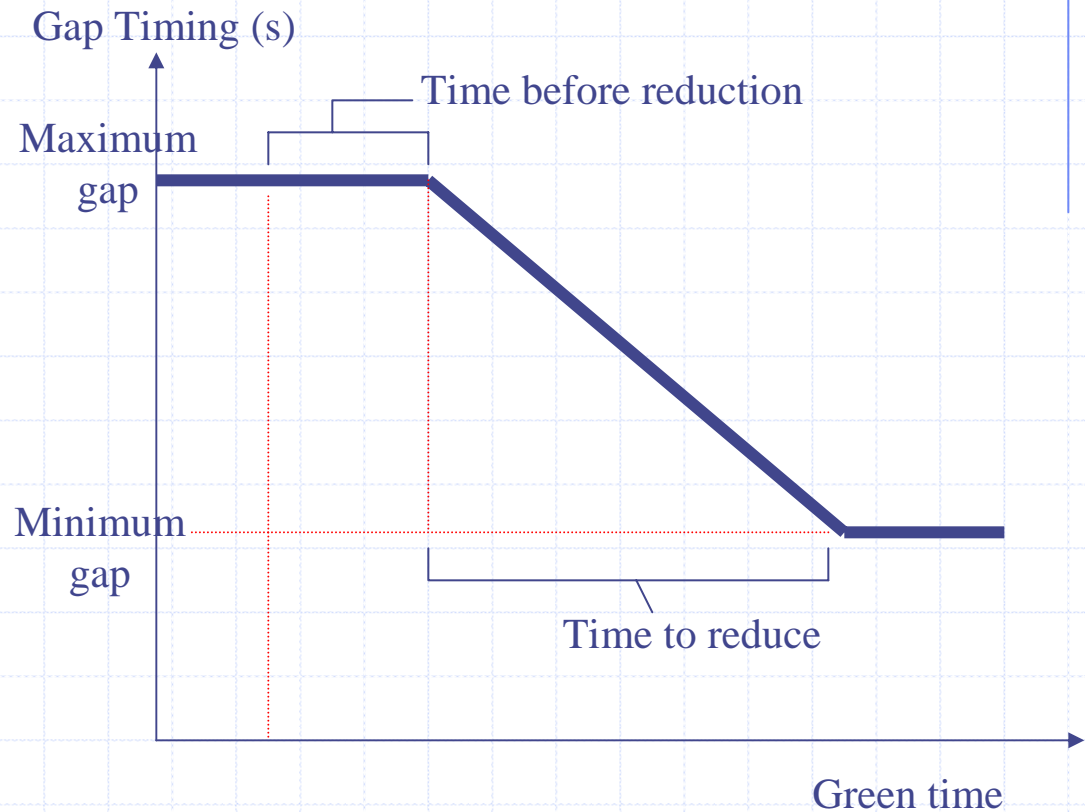

Actuated Controller setting

- ◆ **Initial interval code** [Extensible (default)], [Added initial], or [Computed initial].
 - **Extensible initial** is the method of calculating the variable initial period commonly used in field practice. This method adds the time specified as "**seconds per actuation**" to the minimum initial (green) for each vehicle actuation received by a phase during the yellow and/or red signal (depending on **red and yellow lock** up to a maximum initial time.
 - **Added initial** is similar to extensible initial with the exception that the "seconds per actuation" calculation does not begin until a user specified number of vehicles actuations have occurred. The added initial option is generally used when long minimum green times are specified.

Actuated Controller setting

- Computed initial calculates the amount of time given to each vehicle actuation (computed **seconds per actuation**) during the red signal display of the phase based on the following formula:
- **Maximum initial interval time/ number of actuations** that can be serviced during the minimum initial interval x number or recorded actuations. The total time allowed for the computed initial interval is limited by both the **minimum green** and **maximum initial interval**.

Actuated Controller setting

- ◆ **Minimum gap (MIN GAP)**. This input is the minimum acceptable vehicle gap (MIN GAP) specified by the user. It is also used to specify the end of the gap reduction period when the gap reduction code equals 0 or 1.
- ◆ **Maximum gap (MAX GAP)** defines the gap at the beginning of the gap reduction period. If maximum gap has not been specifically identified as a controller timing parameter to be analyzed or the gap reduction feature is not being utilized, the input should be equal to the vehicle extension . This input can be used to establish the **Time Before Reduction value**. The minimum value accepted by the program is 1.1 seconds.
- ◆ If gap reduction is not being used, the minimum and maximum gap should be equal to the acceptable headway between vehicles.

Actuated Controller setting

- ◆ Red/Yellow lock When red lock is active the controller begins accumulating vehicle actuation for the phase to be used in the calculation of variable initial timing during only the red portion of the phase. Red lock should not be set to active unless the controller being analyzed specifically has a "red locking memory" that is active
- ◆ Yellow Lock [LOCK, or MEMORY on/off, or LOCKING MEMORY on/off, or a similar term and toggle. If this memory lock toggle is "on" (active) vehicle actuation which occur during the yellow and red display of the signal phase are accumulated and remembered in the controller and used in the variable initial calculation and/or to call the phase for service. If the toggle is set to "off" (inactive) it only means the controllers does not remember or count vehicle actuation or place a call for service on a phase that has an unoccupied detector. In no case should the locking memory set to "off" be considered as a Red Lock "on."

Actuated Controller setting

◆ Double (dual)-entry (DUAL ENTRY)

- If dual entry is permitted, a vehicle call on one phase, in the absence of a call on a compatible phase, will automatically place a call on the primary corresponding compatible phase.
- In the standard NEMA phase numbering scheme, compatible dual-entry phases are 1 and 5, 2 and 6, 3 and 7, and 4 and 8.
- Common usage is to have dual entry active on the NEMA standard even-number phases (through movements) and inactive on NEMA standard odd-number phases (left-turn movements)

Standard 8 Phase Sequence

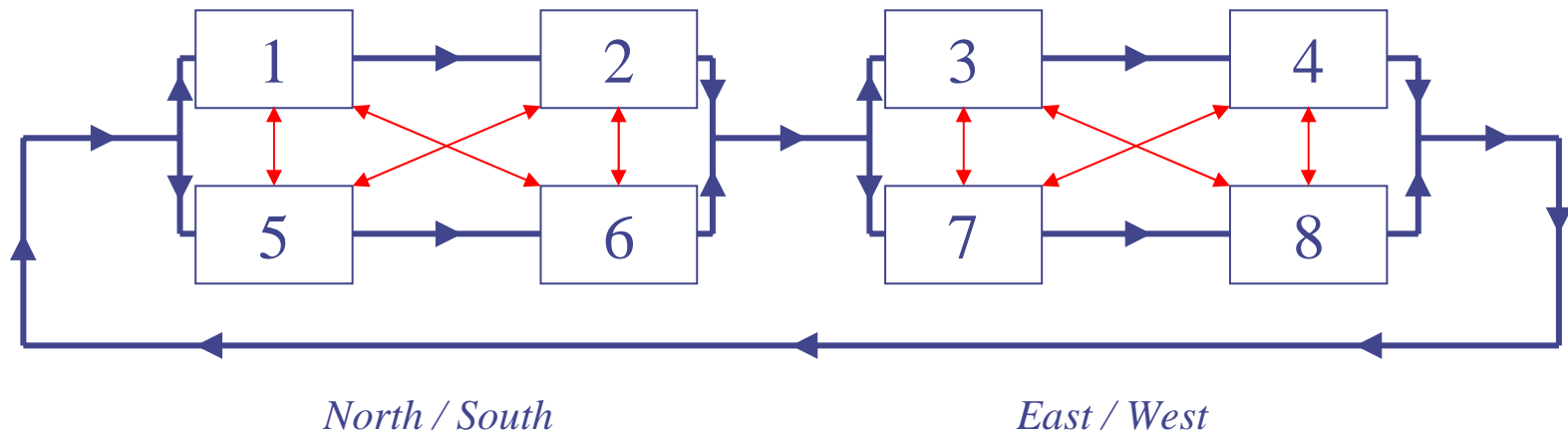

→ = NEMA Phase Sequence

→ = Phases that CAN run concurrently

Actuated Controller setting

- ◆ Minimum vehicle recall code (MIN RECALL or VEHICLE RECALL)
- ◆ Maximum vehicle recall code (MAX RECALL or RECALL TO MAX)
 - If minimum/maximum recall is active, the phase is serviced to minimum/maximum green when there is no demand
 - ◆ Low traffic volumes
 - ◆ Detectors malfunction

Actuated Controller setting

◆ Rest in red

- used to designate when all phases of the controller are allowed to rest in red (RED REST or REST IN RED)
- In the absence of calls or recalls on any phase. If rest in red is set to active for any phase it should be active for all phases.
- General practice is to allow the controller to rest in green on the mainline approaches in the absence of calls. In this case, rest in red would be set to inactive for all phases.

Actuated Controller setting

◆ Lag

- If Lag is active, phase lags the other phase in its phase pair
- The lag phase setting designates which phase of a phase pair displays green first, before the other phase.
- A phase pair is defined as adjacent phases in the same ring on the same side of the barrier on a standard NEMA phase diagram.
- Phase pairs are phases [1 and 2], [3 and 4], [5 and 6], and [7 and 8].
- In a standard NEMA 8 phase configuration operating in **leading dual lefts** on both streets, **phases 2, 4, 6 and 8** are lag phases while **phases 1, 3, 5, and 7** are leading phases.
- For a lead/lag sequence, phase 2 can lead, and phase 1 can lag. This will produce the signal display sequence of phases 2 and 5, then phases 2 and 6, then phases 1 and 6.
- It is also possible to have both left turns lagging by specifying phases 2 and 6 as leading and phases 1 and 5 as lagging.

Actuated Controller setting

◆ Overlap

- An overlap is a vehicle movement, generally a right turn, which is allowed to run concurrently with two standard phases.
- For example, phase 4 right turn movement is defined as overlap
- Usually a 5-section signal head with right arrows controls this type of overlap movement.
- This overlap, is allowed to run concurrently with not only phase 4, under green ball control, but also whenever phase 1 is active in either the phases 1 and 5, or 1 and 6 combination.
- Therefore phases 1 and 4 are "parent" phases to overlap. When overlap is active with phase 1 the signal controlling the overlap movement is generally displaying a green right arrow indication.

Actuated Controller setting

◆ Red revert (RED RVT or RED REVERT)

- Under very light traffic conditions and fully actuated control it is possible **without red revert active** for a phase to go from green to yellow and then back to green without ever displaying a red indication.
- Red revert timing prevents this signal display sequence by forcing the red indication to be displayed after a yellow for at least the red revert time. **Red revert** is generally factory programmed at 2 seconds and seldom changed by the user.

Actuated Controller setting

◆ SIMULTANEOUS GAP

- ◆ This parameter defines if this phase [does, does not] require both phases in a barrier-crossing situation to simultaneously gap-out or have both maximum timers expire to terminate the phase
 - Both NEMA and 170 operational logic specifies that both controller rings, ring 1 and ring 2, must cross the barrier at the same time.
 - This can be accomplished by each of the phases 2 and 6 "gapping-out," "maxing-out," or "forcing-off."
 - With simultaneous gap-out not active, one ring can gap-out and the other can max-out.
 - Additionally, once a phase gaps-out it will stay in that condition, irrelevant of any future vehicle actuations until the phase in the opposite ring either gaps-out or maxes out and then both phases cross the barrier.
 - With simultaneous "gap-out" active, each of the phases cannot cross the barrier until both phases have been terminated in the same manner, by either "gap-out" or both "max-out." Additionally, if a phase initially "gaps-out" and then, due to increased vehicle demand, vehicle arrivals are less than the extension time, the "gap-out" flag for that phase is removed.
 - With simultaneous "gap-out" active, the vehicle headways on both phases must currently be exceeding the gap-in-effect.
 - The inactive status (code 0) for this function generally produces a quicker reacting signal installation and shorter cycle lengths.

Actuated Controller setting

◆ Conditional Service (COND SERVICE)

- This indicates if this phase [can, cannot] be serviced twice during a cycle.
- This conditional (dual) service feature cannot be requested for lag phases and cannot be requested for coordinated controllers
- When a heavy left-turn demand exists at an isolated intersection (not coordinated), it may be desirable to service one of these left-turn phases twice in the same controller cycle.
- The conditional service entry, under a specific set of circumstances, allows the left to be serviced first as a leading phase and then as a lag phase.

Detector Configuration for Actuated Controller

◆ Reference?